

Model: DOC Flush™

Differential Oil Changer Parts

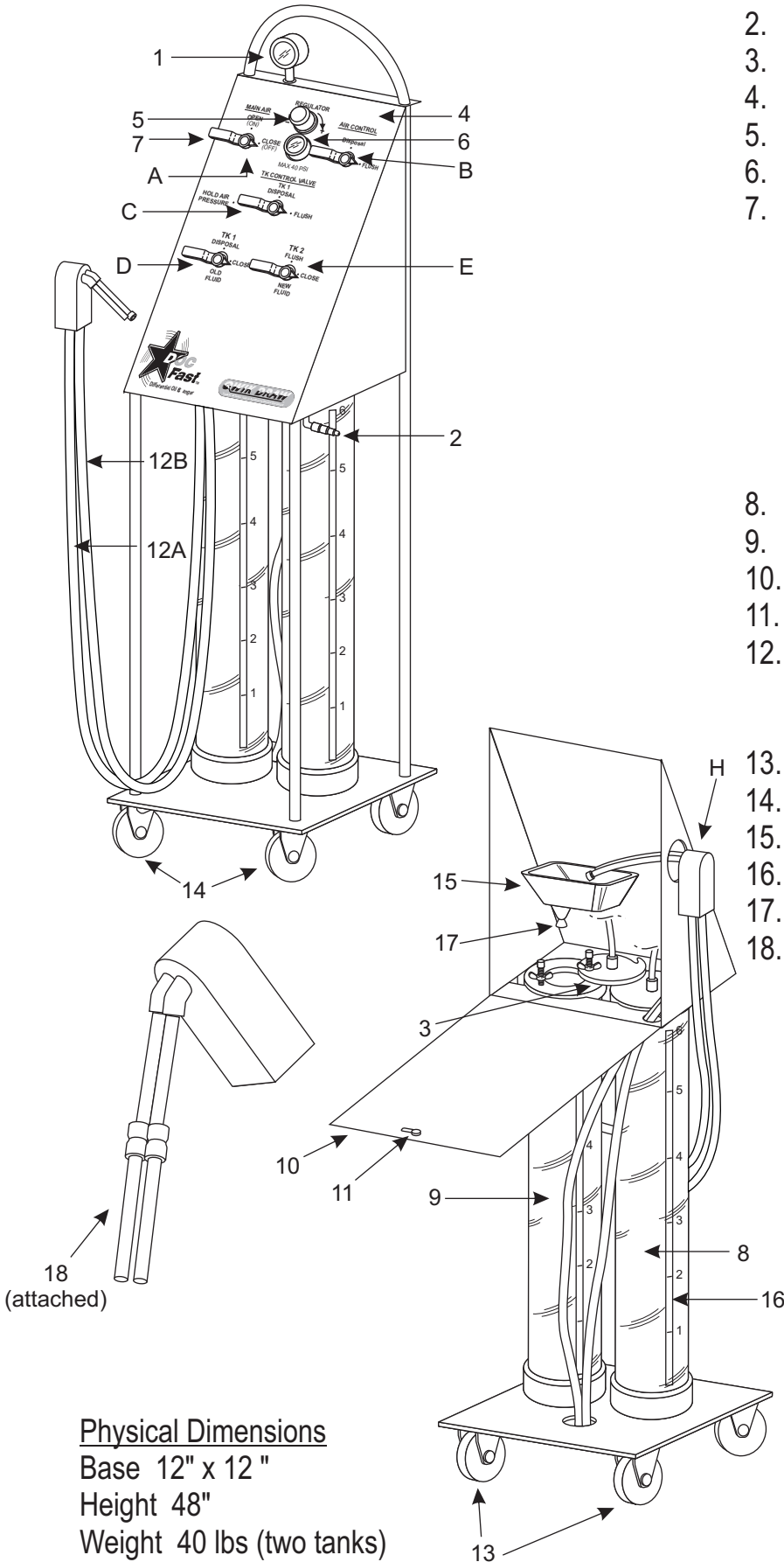

1. Compound Gauge
2. Shop Air Coupler Fitting
3. Quick Open & Close Lid
4. Control Panel
5. Air Regulator Adjustment Valve
6. Air Regulator Pressure Gauge
7. Control Valves
 - A. Main Air Valve
 - B. Air Control Selection Valve
 - C. TK Control Air Selector Valve
 - D. Old Fluid TK 1 Control Valve
 - E. New Fluid TK 2 Control Valve
 - H. DOC Universal Vacuum Nozzle (DOC-UVN)
8. Old Fluid TK 1
9. New Fluid TK 2
10. Door Panel
11. Door Panel Lock
12. Nozzle Hoses
 - A. New Fluid Hose
 - B. Old Fluid Hose
13. 3" Heavy Duty Casters
14. 3" Swivel Casters
15. Fluid Funnel
16. Liter Indicator Measuring Strip
17. Fluid Funnel Cork
18. 1/4" Tube Adaptor

Physical Dimensions

Base 12" x 12"

Height 48"

Weight 40 lbs (two tanks)