

Model: Station Flush™

Qwik Draw Fluid Exchanger

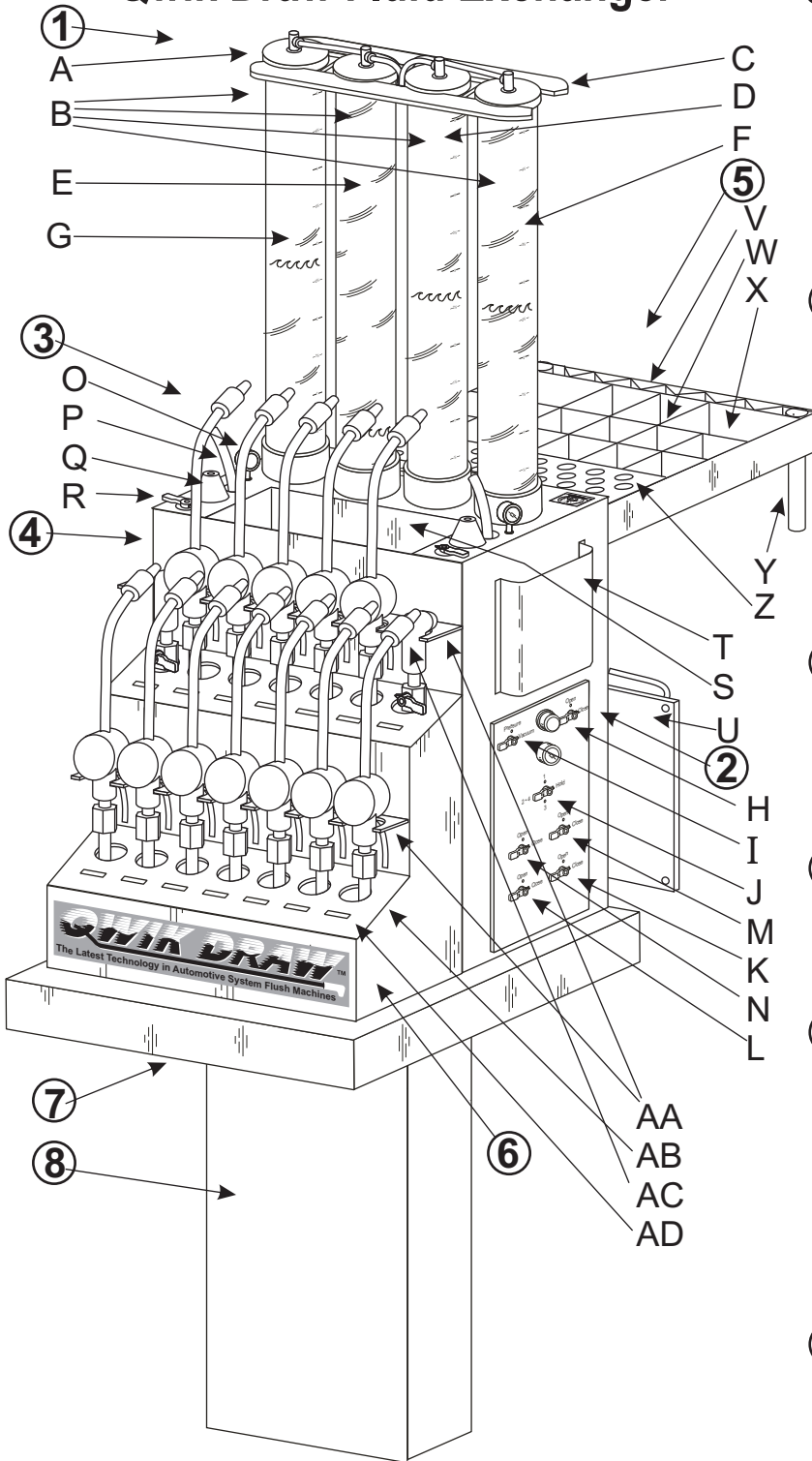

Machine Physical Dimensions

Base 30" x 18"

Height 90"

Approx. Weight 249 lbs

Tech Tray Dimensions

30" x 30" x 5"

Fluid Exchanger Parts

- ① Qwik Draw Coolant Flush Machine
 - A. Aluminum Caps
 - B. Fiberglass Tanks 5 Gallon Capacity
 - C. Aluminum Brackets
 - D. New Dex Coolant Tank
 - E. Old Coolant Tank
 - F. New Zerex Coolant Tank
 - G. New Ethylene Glycol Tank
- ② Qwik Draw Aluminum Control Panel
 - H. Air Control Selection Valve (Orange)
 - I. Main Air Valve (Green)
 - J. TK Control Air Selection Valve (Silver)
 - K. TK 1 Old Coolant Valve (Black/Yellow)
 - L. TK 2 New Coolant Ethylene Glycol Valve (Green/Yellow)
 - M. TK 3 New Dex Coolant Valve (Yellow)
 - N. TK 4 New Zerex Coolant (Red/Yellow)
- ③ Aluminum Control Base
 - O. 25 Hg Guage
 - P. 3/8 Hose Holder
 - Q. Rubber Cone Holder
 - R. Control Selector Valve (Green)
- ④ Stainless Steel Retrofit Enclosure
 - S. Stainless Steel Trash Chute Holder
 - T. Stainless Steel Fender Cover
 - U. Stainless Steel Enclosure Access Door
- ⑤ Stainless Steel Tech Tray
 - V. Stainless Steel Zig-Zag Tool Holder
 - W. Aluminum Dividers: Spray Can, Fluid and Lubricant Bottles, etc.
 - X. Shop Rags Holder Compartment
 - Y. Stainless Steel Drain Drip Funnel Holder Tube
 - Z. Stainless Steel Drain Drip Fluid Bottle Holes
- ⑥ Stainless Steel 14 Gun Fluid Base Console Holder
 - AA. 14 Gun Fork Support
 - AB. 14 Fluid House Dividers
 - AC. U.V.N. Handle
 - AD. Aluminum Tags
- ⑦ Stainless Steel Curb Cover
- ⑧ Stainless Steel Telescopic Trash Chute